

## Overview

The PaxLock Pro represents Paxton's 3rd generation of electronic door handle; offering a robust, featureful and aesthetically pleasing product suitable for a multitude of installations.

The new patented design has been created to be both simple to install, intuitive to use and backed up by Paxton's market leading 5 year warranty.

Offering two modes of operation the user can choose to use the PaxLock Pro as a standalone offline device, or connect it to a Paxton10 system via a Paxton10 Wireless connector.



## Features

- Dual frequency reader
- Wireless real-time event reporting
- When PaxLock Pro - Latch is unlocked the handle moves freely
- Dual standalone and online functionality in one unit





## System

Maximum total tokens/users - Standalone	100 card packs (up to 5,000 tokens/users)
Maximum total tokens/users - Online	50,000
Token compatibility	Paxton, EM4100/02, MIFARE®, MIFARE ° Classic, MIFARE® DESFire® EV1, MIFARE Plus®, MIFARE Ultralight®, MIFARE Ultralight C®, MIFARE Mini®, HID® Prox, Sony®, FeliCa Lite-S
Stored events	16,000
Hands free compatible	Yes - Touch to enter
Door open time	1-60 Seconds
Silent operation	Yes
Door traffic	Typically up to 75 uses per day



## Electrical

Battery Type	4x AA 1.5V Alkaline
Battery Life	55,000 operations



## Communication

Wireless	Bluetooth® 2.4GHz (IEEE 802.15.4)
Default channel	25
Recommended wireless devices per Paxton10 Wireless connector	10
Typical wireless range	Bluetooth® 15m/50ft
Encryption	AES128



## Hardware

Warranty	Paxton 5 year
----------	---------------



## Environment

Operating temperature	Reader side: +32°F ~ +120°F
	Battery side: +32°F ~ +120°F
IK Rating	N/A
Fire Resistance	N/A



## Dimensions

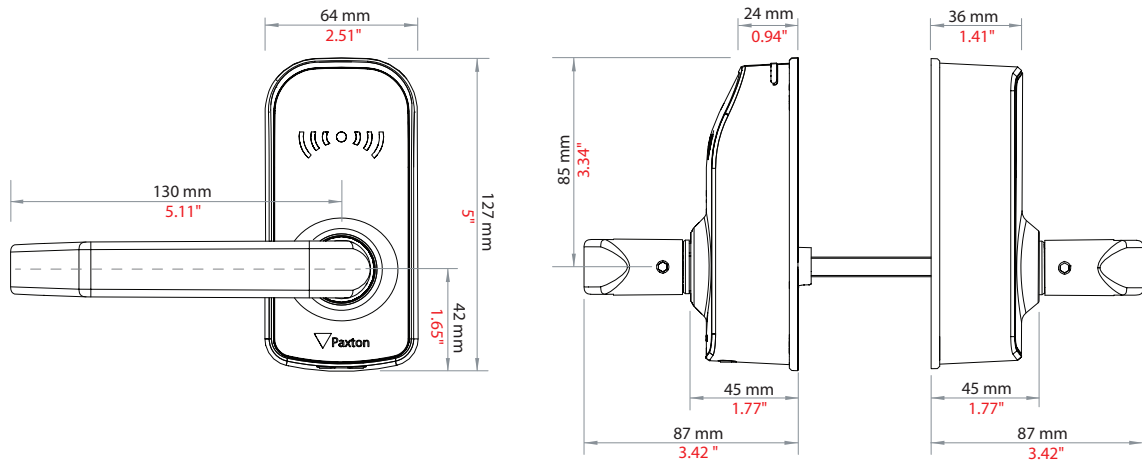

Certifications: FCC Part 15, ISED, UL 294, CSA C22.2 No 205.

